

### Modular Systems with flexible Automation



#### Company

The engineering consultants IBN are based in Niendorf an der Stecknitz, Schleswig Holstein. Their key area of competence is in process control for the food industry. With its PMS production management system, the company now already complies with EU Directive EG178/2002, that comes into force on 01.01.2005: IBN systems implement customised materials tracing solutions as specified in the EU Directive. IBN's largest customer is Schröder GmbH & Co. KG, which was founded in Lübeck in 1928. Schröder Kombinator supplies worldwide processing plants, machines, and automation for the food industry.

Plants in the food industry need to have a modular structure. Each unit has to be integrated in a line that is configured for the particular product being processed. This requires the use of a scalable automation system. The operator level must have a standard design – from the text display for manual control, to a medium-sized graphic panel, right up to a production management system with data archiving for product tracing and the evaluation of tests in the laboratory. Moeller's XSystem allows the machine builder to adapt the automation to the process engineering modules at hand – an invaluable benefit in terms of continuity and flexibility for visualization, HMI and control systems.

With Moeller's XSystem, IBN could adapt to the automation to the process engineering modules at hand: each unit is equipped with its own PLC that can be networked via the fieldbus. Moeller's compact MI4 text display (MI4-101-KC1), integrated in the stainless steel housing, can be plug connected by the customer to a unit for local operation. The systems can be equipped at a later date with

an HMI touch panel or a SCADA system. With Moeller's MV4 touch panel, IBN was able to create the same operator interfaces as on the SCADA system. This is what Torsten Krüger, technical manager at IBN, had to say: "Our largest customer, Schröder Kombinator, standardises its systems using modular elements. With previous automation components, commercial

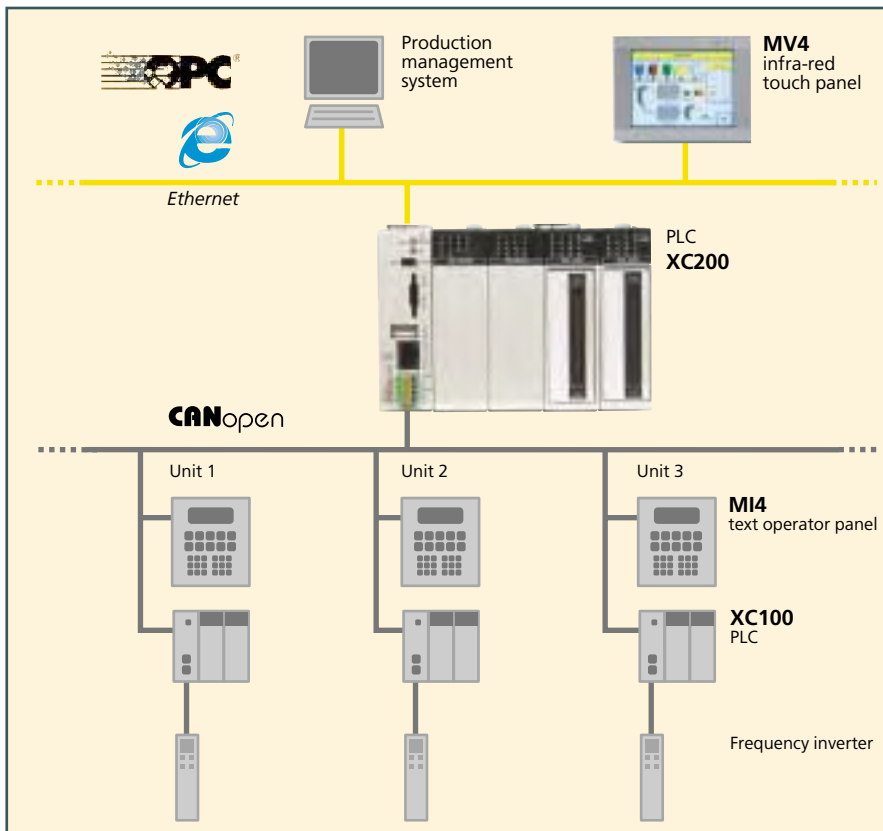

such as process parameters. The process data is observed from the monitor, managed or assigned parameters. The operator controls the system and activates valves or motors via the monitor.

The automation system consists of a combined IP54 control/load cabinet, an MV4 touch panel, several XC100 CPUs in a modular arrangement, as well as digital/analog I/O modules. Frequency inverters are designed for mounting to motors.

The software solution consists of the following:

- Motor control and monitoring for the final control elements contained,
- Continuous closed-loop controllers for temperature, pressure, flow and speed controls,
- Two-point controller for hot water heater,
- Valve control and monitoring for valves with and without feedback.
- Recipe management,
- Automatic program for initial mixing, metering or production,
- Test report generator for test evaluations.

The valves are equipped with pneumatic actuators, solenoid valves and indicators.

requirements only allowed us to implement this step with the software. This meant that when buying the first units, the customer had to know exactly how large the final extension of their system was going to be so that we could choose the most suitable automation device. Each extension therefore involved enormous additional costs. With the XSystem we are at last able to implement the modular system with the hardware as well." Each unit is equipped with a compact XC100 with its own intelligence. Today's IBN customers create one complex system from several units. An XC200 is used as a master controller for automatic mode. It is connected via RS232 or CAN bus to an MV4 touch panel for implementing small-scale solutions or as an operator unit at the machine. Large solutions can be implemented by linking the XC200 via Ethernet and OPC server to the IBN SCADA or PMS system.

Thanks to the XSystem, IBN can offer its customers a scalable system. Customers can now adapt system expansions flexibly to the technical requirements at hand and the

financial resources available rather than being restricted by the capabilities of the automation selected.

### Expansion for recipe and automatic mode management

IBN's project at Schröder involved a solution for recipe and automatic mode management. The MV4 had been introduced at Schröder a year and a half before and is integrated in a tried and tested visualization concept (InTouch) which is to be retained as much as possible. However, with the technical features of the MV4, requirements increased in terms of the amount of process data to be handled. Furthermore, both visualization systems had to have standard user interfaces.

The new Schröder Kombi-LOG system controls, regulates and monitors the system. A graphic operator panel ensures simple operation and process control. The system also handles the management of master data

## Conclusion

The operating personnel in the laboratory and in production have quickly become familiar with the MV4 touch panel and the SCADA system with their standard operator interfaces. A line can even be reconfigured by the company personnel for a new product, such as margarine, cooking fats, dressings, ketchup or bakery, fat or sugar products – without having to adapt the software. Other benefit: The laboratory systems can be networked with the SCADA systems. This facilitates an upscaling from the laboratory to the production system. This technological step alone reduces the costs of the electrical system for creating a plant control by 30 percent.